

# maXYmos TL / TL ML / TL L

Type 5877B...

## XY Monitor for complex evaluation of curves

The maXYmos TL (Top Level) captures, analyzes and evaluates XY curves of two measurands that have to stand in a precisely defined relationship to each other. Such curves arise in applications such as

- Press fitting of bearings or valve seat rings
- Riveting and flanging of casing parts
- Turning and swiveling of joints
- Turning of key switches
- Movement of drawer slides
- Compression and extension of shock absorbers
- Pressing of snap-in elements

The measurement curves can be used to assess the quality of an individual stage of production, an assembly or the product as a whole.

### Description

The functions of this XY monitor range from simple, single-channel force-displacement monitoring to complex multi-channel applications for use in assembly and product testing. The monitor, which can have up to eight cascaded channel pairs, is designed to satisfy the most demanding users who require maximum user-friendliness, user comfort and flexibility. With a wide range of powerful evaluation objects, even very complex XY curves can be evaluated. Building on the maXYmos BL (Type 5867B...), the maXYmos TL offers a whole range of additional evaluation possibilities. For example, the GET-REF object is able to determine the coordinates of significant points on a curve, e.g., the position of a snap-in point, and pass them to a CALC object. This then calculates, e.g., the distance between two such snap-in points and evaluates it.

- Up to 8 XY channel pairs via cascaded measuring modules (MEM)
  - The main features of each MEM:**
  - Curve capture according to  $Y=f(X)$ ,  $Y=f(X,t)$ ,  $Y=f(t)$ ,  $X=f(t)$
  - Curve evaluation with NO-PASS, LINE-X, LINE-Y, UNIBOX, ENVELOPE, GET-REF, CALC, GRADIENT-Y, GRADIENT-X, HYSTERESIS-Y, HYSTERESIS-X, TUNNELBOX-X, TUNNELBOX-Y, SPEED, AVERAGE, BREAK, INFLEXION, INTEGRAL, DIG-IN, DELTA-Y, TRAPEZOID-X, TRAPEZOID-Y, TIME, DISPLACEMENT RANGE, FORCE RANGE, PASS-THROUGH BOX
  - Up to 10 evaluation objects (EOs) per curve
  - Dynamic referencing of evaluation objects in X and Y directions



- 108 measurement programs and 20 master programs
- Measurement curve with up to 8 000 XY value pairs
- Short evaluation time
- EtherNet TCP/IP for measurement data, remote maintenance and channel cascading
- Choice of bus types available via menu: PROFIBUS DP, EtherNet/IP, PROFINET, EtherCAT
- Dig-IO (24 V) for control and results
- 2 switching signals on X or Y threshold
- 2+1 USB for USB stick and notebook
- Channel X: Pot,  $\pm 10$  V, LVDT, incremental, SSI
- Channel Y: Strain gauge,  $\pm 10$  V,  $\pm 10$  V (2 measurement ranges), or piezoelectric sensors
- Multiple data export formats, e.g. Q-DAS, QDA9, IPM 5.0, XML, CSV, PDF
- Desktop, wall or front panel mounting; can be repositioned in a few easy steps
- Informative NOK cause diagnosis, process value trend patterns, etc.
- Process value table with free choice of contents
- Selected process values for the curve graph
- Warning and alarm messages, e.g., NOK in series
- Access protection with various levels of access
- Display module (DIM) with 10,4" color touch screen and front-mounted USB slot
- Sequencer Mode (logical sequence control)
- maXYmos TL ML**
  - User management
  - Advanced port management
  - Audit trail
  - Grid lines for better visualization of the measurement results
  - OPC-UA (Demo Version)
  - FDA and MDR conform process monitoring

For more information visit [www.kistler.com/maxymos](http://www.kistler.com/maxymos)

Page 1/11

This information corresponds to the current state of knowledge. Kistler reserves the right to make technical changes. Liability for consequential damage resulting from the use of Kistler products is excluded.

©2016 ... 2020, Kistler Group, Eulachstrasse 22, 8408 Winterthur, Switzerland  
Tel. +41 52 224 11 11, Fax +41 52 224 14 14, [info@kistler.com](mailto:info@kistler.com), [www.kistler.com](http://www.kistler.com)  
Kistler is a registered trademark of Kistler Holding AG.

**Technical data**

**Measuring and evaluation module (MEM)**

Degree of protection	IP	40
Operating temperature	°C	0 ... 45

**Measuring channels**

Number	1 X-channel, 1 Y-channel	
Sampling rate X/Y max.	kHz	20
Resolution per (analog) channel	bit	24
Accuracy class	%	0,3
Low-pass filter per channel (in stages)	Hz	0,1 ... 2 000

*Sensors channel X*

<b>Sensor Type 1</b>	Potentiometer	
Linearity error	%FS	±0,05
Track resistance	kΩ	1 ... 5
Supply voltage	V	4 (4,16)
Connection system	3-wire	
Wiper current	μA	<1,0
<b>Sensor Type 2</b>	Process signal ±10 V	
Signal output	V	±10
Linearity error	%FS	±0,05
Transmitter supply	VDC	24 ±5 %
max. mA X+Y Channel	mA	500
<b>Sensor Type 3</b>	Incremental TTL	
Signal output	Sinus/Cos, RS-422 (A+B)	
Reference marker	yes	
Counting depth	bit	32
Counting frequency	MHz	10 (RS-422)
	MHz	1 (sine/cos)
Impedance	Ω	120
<b>Sensor Type 4</b>	Inductive	
Principle	LVDT, half-, full-bridge	
Sensor supply	Veff	1,8 ±5 %
	kHz	5,2 ±0,5 %
Linearity error	%FS	±0,05
Frequency range (-3 dB)	kHz	0 ... 1
<b>Sensor Type 5</b>	SSI	
Signal output	RS-422	
Clock frequency max.	MHz	1

*Sensors channel Y*

<b>Sensor Type 1</b>	Piezo
Measuring ranges see following page 3	

Range selection		automatic
Drift	pC/s	0,05
Linearity error	%FS	±0,05
TKE	ppm/K	<±100
Frequency range (-3 dB)	kHz	0 ... 5
Low-pass filter (in stages)	Hz	in stages 0,1 ... 2 000
<b>Sensor Type 2</b>	DMS	
Measuring range	mV/V	0 ... ±5
Supply voltage	VDC	5 ±5 %
Connection system	4-wire, 6-wire	
Bridge resistance	Ω	≥300
Linearity error	%FS	±0,05
Frequency range (-3 dB)	kHz	0 ... 5
<b>Sensor Type 3</b>	Process signal ±10 V	
Signal output	V	±10 ±10 (2 measurement ranges)
Linearity error	%FS	±0,05
Transmitter supply	VDC	24 ±5 %
max. mA X+Y Channel	mA	500

**Cycle control**

Start – Stopp	Dig-Input/Fieldbus/Threshold X/Threshold Y/ Time/Manual
---------------	--

**Measuring functions**

Measurement curve according to  $Y=f(X)$ ,  $Y=f(t)$ ,  $Y=f(X,t)$ ,  $X=f(t)$

**Curve memory**

Current curve	XY-pairs	max. 8 000
Historic curves (for NOK diagnosis)		the last 500

**Evaluation Objects (EOs)**

EO types NO-PASS, LINE-X, LINE-Y, UNI-BOX, ENVELOPE, GET-REF, CALC, GRADIENT-Y, GRADIENT-X, HYSTERESIS-Y, HYSTERESIS-X, TUNNELBOX-X, TUNNELBOX-Y, SPEED, AVERAGE, BREAK, INFLEXION, INTEGRAL, DIG-IN, DELTA-Y, TIME, TRAPEZOID-Y, TRAPEZOID-X, DISPLACEMENT RANGE, FORCE RANGE, PASS-THROUGH BOX

Reference points Absolute X, Dynamic: Block point X, Dynamic: X on trigger Y, Referencing in X and Y directions possible

Editing Remote VNC®, via touchpanel

**Data export**

Protocol	Q-DAS®, QDA9, IPM 5.0
Format	XML, CSV, PDF
Destination	USB, Server
Medium	USB, Ethernet

5877B\_003-273e-05.20

### Visualization

Type	across VNC®, or Display Modul (DIM)
------	-------------------------------------

### Serielle interfaces

Ethernet	TCP/IP 100 Base TX with 2 Port Switch
USB	3 x USB (Device + Host)
BUS	PROFIBUS DP PROFINET, EtherCAT, EtherNet/IP, 2 Port Switch

### Dig-In/Out

Norm		DIN EN61131
Level state "0"	V	0 ... 5
Level state "1"	V	15 ... 30
Number of inputs		22
Input current max.	mA	8 (at 24 V)
Number of outputs		23
Output current max. (per channel)	mA	500 (at 24 V)
Output current max. (in total)	mA	1500 (at 24 V)

### Measurement programs

Number measuring programs		108
Number master programs		20
Switchover via		Menu/Dig.-In/BUS
Switchover time	ms	<50

### Switching signals

Number		2
Channel assignment		X or Y (selectable)
Switching point		Threshold X exceed/underrun Threshold Y exceed/underrun
Output		Dig.-Out or Fieldbus
Mode		Free-running or latch
Influence on evaluation		No

### Real-time reactions

Switching signals	ms	<1
EO type "NO-PASS"	ms	<1

### Power supply

Voltage VDC	24	(18 ... 30)
Power consumption (typical)	VA	45
Power consumption (max.)	VA	80
Lossy line (MEM)	W	18
Screw-type/plug-in connector,		1 supplied with device Wago, order no. 734-103/037-000 Housing: order no. 734-603

### Environment

Working temperature	°C	0 ... 45
Storage temperature	°C	0 ... 50
IP degree of protection (EN 60529)		
– Connector and cable running downwards	IP	53
– Standard rail version	IP	20

### Display module (DIM)

Size	Inches	10,4
Color		yes
Touchscreen		yes
Resolution	Pixels	800x600 (SVGA)
Technology		TFT-LCD
Backlighting		LED
Supply voltage (of MEM)	VDC	24
Power consumption	VA	6
IP degree of protection (EN 60529)		
– Front	IP	65
– Rear	IP	53
Operating temperature range	°C	0 ... 45



#### Sensor Channel Y

Measuring range		Number 4
<b>maXYmos TL Standard Type 5877B0</b>		
Measuring range 1	pC	±100 ... ±1 000
Measuring range 2		±1 000 ... ±10 000
Measuring range 3		±10 000 ... ±100 000
Measuring range 4		±100 000 ... ±1 000 000



#### Sensor Channel Y

Measuring range		Number 4
<b>maXYmos TL ML Medical Low measuring range Type 5877B2</b>		
Measuring range 1	pC	±0 ... ±40
Measuring range 2		±40 ... ±400
Measuring range 3		±400 ... ±1 000
Measuring range 4		±1 000 ... ±10 000



#### Sensor Channel Y

Measuring range		Number 4
<b>maXYmos TL L Low measuring range Type 5877B3</b>		
Measuring range 1	pC	±0 ... ±40
Measuring range 2		±40 ... ±400
Measuring range 3		±400 ... ±1 000
Measuring range 4		±1 000 ... ±10 000

5877B\_003-273e-05.20

**The system concept**

**Basic components**

The maXYmos TL consists of two basic components: the measuring and evaluation module (MEM), which works entirely autonomously and supports one XY channel pair each, and the display module (DIM).



DIM Type 5877AZ000      Type 5877B0    Type 5877B2  
Type 5877B3

**MEM with display module**

The MEM and DIM can either be installed separately from each other, in which case they are connected only via the optional connecting cable type 1200A161A2,5/5.



.... or they can be used as a compact unit. In this case the MEM is inserted into the rear slot of the DIM, forming a secure mechanical and electrical connection:



**MEM as black box module**

Since the measuring and evaluation module (MEM) works entirely autonomously, it can also be operated without the DIM. In this case, setup and process visualization are carried out via the graphical user interface (GUI), which can be transferred onto a PC. Access is by VNC via the Ethernet interface or USB.



**Expandable for up to eight XY channel pairs**

For this purpose, the MEMs are connected to the Ethernet interface via patch cables. External switches are not required. The Ethernet is simply looped through the MEMs via the In-Out sockets.

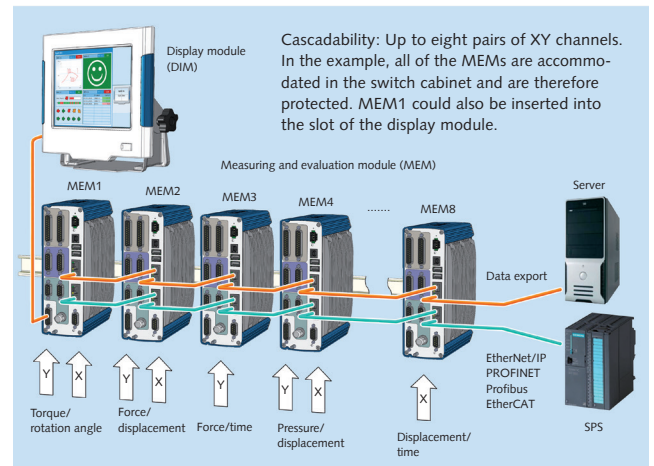

5877B\_003-273e-05.20

**Evaluation objects (EOs) for maXYmos**

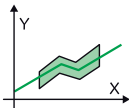
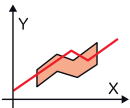
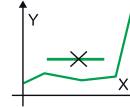
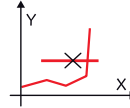
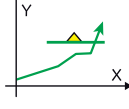
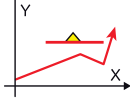
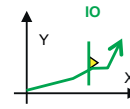
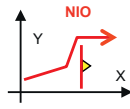
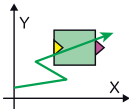
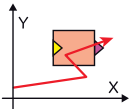
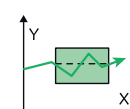
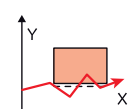
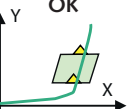
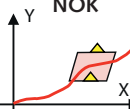
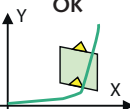
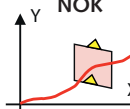
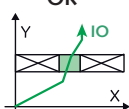
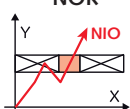
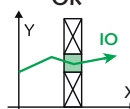
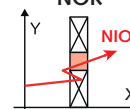
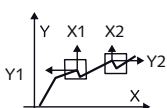
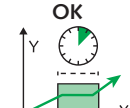
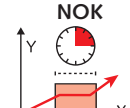
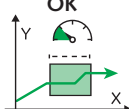
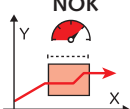
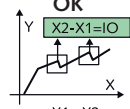
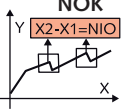
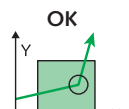
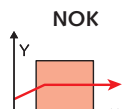
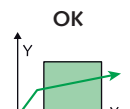
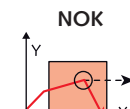
<p>The measurement curve must not cross the upper or lower line of the envelope. This evaluation object is easy to master.</p>	<p><b>Type ENVELOPE</b></p> <p>OK  NOK </p>	<p>The line may not be crossed. Otherwise, NOK and "NO-PASS" real-time signal.</p>	<p><b>Type NO-PASS</b></p> <p>OK  NOK </p>
<p>The line must be crossed once. An X-value at the point of intersection is monitored.</p>	<p><b>Type LINE-X</b></p> <p>OK  NOK </p>	<p>The line must be crossed once. An Y-value at the point of intersection is monitored.</p>	<p><b>Type LINE-Y</b></p> <p>OK  NOK </p>
<p>Entry and exit as specified. No crossing of "closed" sides allowed. Each side can be defined as entry or exit.</p>	<p><b>Type UNI-BOX</b></p> <p>OK  NOK </p>	<p>Evaluates the average of all Y-values in the box region.</p>	<p><b>Type AVERAGE</b></p> <p>OK  NOK </p>
<p>Entry and exit as specified. No crossing of "closed" sides allowed. Each side can be defined as entry or exit.</p>	<p><b>Type TRAPEZOID-X</b></p> <p>OK  NOK </p>	<p>Entry and exit as specified. No crossing of "closed" sides allowed. Each side can be defined as entry or exit.</p>	<p><b>Type TRAPEZOID-Y</b></p> <p>OK  NOK </p>
<p>Entry and exit as specified. Crossing of the "closed" sides generates a real-time signal.</p>	<p><b>Type TUNNELBOX-X</b></p> <p>OK  NOK </p>	<p>Entry and exit as specified. Crossing of the "closed" sides generates a real-time signal.</p>	<p><b>Type TUNNELBOX-Y</b></p> <p>OK  NOK </p>
<p>Box detects significant curve features and their XY coordinates in the expectancy range. This information can be used as reference points for other EOs or as an input for the CALC object.</p>	<p><b>Type GET-REF</b></p> 	<p>Evaluation criterion is the time between the entry and exit points in a special box.</p>	<p><b>Type TIME</b></p> <p>OK  NOK </p>
<p>Evaluation criterion is the speed between the entry and exit points in a special box.</p>	<p><b>Type SPEED</b></p> <p>OK  NOK </p>	<p>Object references two selectable process values and performs calculations, e.g. the X-difference between two ripples, and evaluates them.</p>	<p><b>Type CALC</b></p> <p>OK  NOK </p>
<p>A defined gradient change is expected within the expectancy range (box) and can be used as a further switching condition in the sequence.</p>	<p><b>Type INFLEXION</b></p> <p>OK  NOK </p>	<p>Provides NOK and online signal in case of sudden gradient change within an expectancy range (box), e.g. in case of tool breakage.</p>	<p><b>Type BREAK</b></p> <p>OK  NOK </p>

5877B\_003-273e-05.20

**Measuring and evaluation module (MEM)**

**Interfaces**

The module, which features an XY channel pair and all data and control interfaces, forms the heart of the XY monitor.

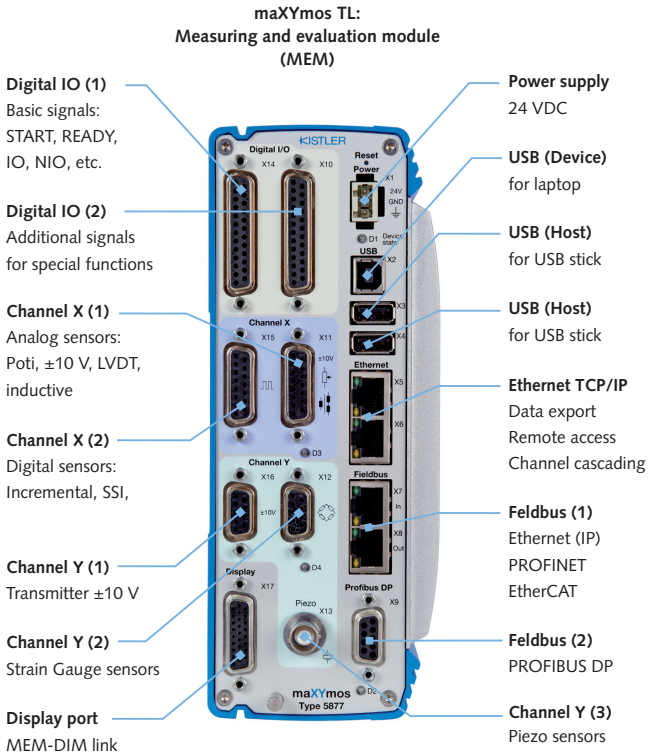

Evaluates the X-Hysteresis between forward and reverse curves on a horizontal line.	<b>Type HYSTERESIS-X</b> OK NOK 
Evaluates the Y-Hysteresis between forward and reverse curves on a vertical line.	<b>Type HYSTERESIS-Y</b> OK NOK 
If the curve throughput is within the defined range, the system checks for the presence of a digital signal.	<b>Type DIG-IN</b> OK NOK 
If the curve throughput is within the defined range, the maximum curve displacement is determined and verified between the advancing and the returning curve.	<b>Type DELTA-Y</b> OK NOK 
Evaluates the gradient dX/dY between two horizontal lines.	<b>Type GRADIENT-X</b> OK NOK 
Evaluates the gradient dX/dY between two vertical lines.	<b>Type GRADIENT-Y</b> OK NOK 
The area beneath the curve is determined and evaluated.	<b>Type INTEGRAL</b> OK NOK 
Evaluates the displacement end position and detects the max. value  The curve must reach the X range. The upper limit must not be reached.	<b>Type DISPLACEMENT RANGE</b> IO NIO 
Evaluates the force end position and detects the max. value  The curve must reach the Y range. The upper limit must not be reached.	<b>Type FORCE RANGE</b> IO NIO 
Evaluates passing through.  The curve must pass the whole box in the preset direction. Evaluation is done over the whole range.	<b>Type PASS-THROUGH BOX</b> IO NIO 

5877B\_003-273e-05.20

### Sequencer mode

The Sequencer Mode in the maXYmos TL allows programming of sequence controls, which are used to control the processes. An independent program can be created for every measurement program, using the freely programmable digital input and outputs to poll or output special, process-relevant conditions, for example. The following elements are available:

#### Important features of maXYmos TL sequencer mode:

- 7 freely programmable digital inputs
- 7 freely programmable digital outputs
- Up to 256 elements for each measurement program
- "Cam function" for the X and Y axis
- MP toggle function
- 20 master measurement programs
- 108 regular measurement programs
- 100 variables



**MP Switching element SWITCH BACK**, by using this element you can change to and return from one of the 20 master measurement programs in one of the 107 sub-measurement programs.



**CALCULATOR element**, by using this element you are able to calculate with determined values.



**MEASURE Start/Stop element**: this element starts and stops the measurement. When measurement stops, evaluation is performed according to the parameterized evaluation elements.



**TIMER element**: this element delays execution of the subsequent element by the configured time. Use as a dwell time under force, for example.



**IF/ELSE element**, this element permits a conditional branch, i.e. a branch in the sequential program according to the query condition or result.



**Restart element SEQUENCE RESET**, branching option to the start of the sequence.



**PIEZO OPERATE element**, this element is used to perform a variable measure/reset of the integr. charge amplifier included in the sequence.



**THRESHOLD element**, this element serves to record the learned positions on the X and Y axes. These positions act as a progressive switching or query condition in the sequence.



**OUTPUT element**: when this element is activated, the corresponding configured output is set on the device.



**INPUT element**: when this element is activated, the system waits for the configured digital input signal and then continues the sequence.



**DIALOG element**, this element enables interaction with the user. It can be used, for example, to forward useful information to the user. The dialog must be confirmed by the user at the visualization or will be hidden automatically after a configured period of TIME.



**ZERP TARA element**, this ZERO TARA element can be used to set the sensor to zero on the X or Y channel in the sequence.



**BARCODE-reader element**, this element can be used to read a barcode.

**Product testing example:** Distance check between two snap-in points of a latch. The two GETREF boxes supply the coordinates of the snap-in points to the CALC objects. These calculate and evaluate the distances in the X and Y directions.

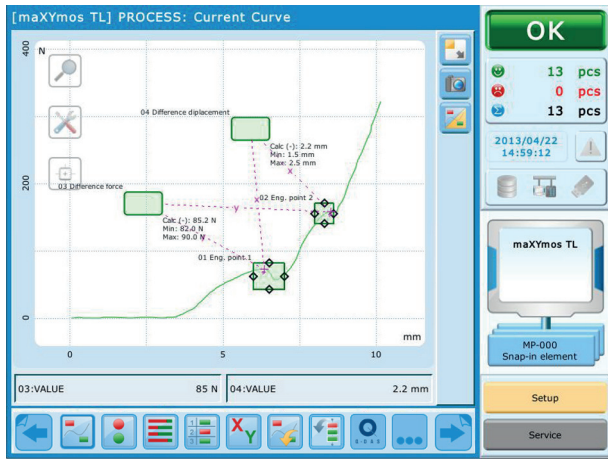

### Housing concept and installation variants

With the universal housing concept, different mounting configurations can be realized in a few easy steps. This allows the machine designer to change to a different mounting configuration at any time.

### Desktop and wall mounting

A desktop unit can be changed into a wall-mounted version in a few easy steps.



### Front panel mounting

After removing the fixing bracket and rear frame, push the display through the front panel opening. Then screw the frame back on. The measuring module (MEM) can now be pushed into the slot of the display module if required.



### DIN Rail mounting

The measuring module (MEM) can be mounted on a DIN rail with an optional fastening clip. This makes it possible to house the sensitive connection area of the MEM inside the control cabinet, where it is well protected, while placing the better protected display module (DIM) in the visible area.

Advantages: There is only a monitor cable leading to the display. At the same time, the degree of protection in the monitor area is increased to IP65.

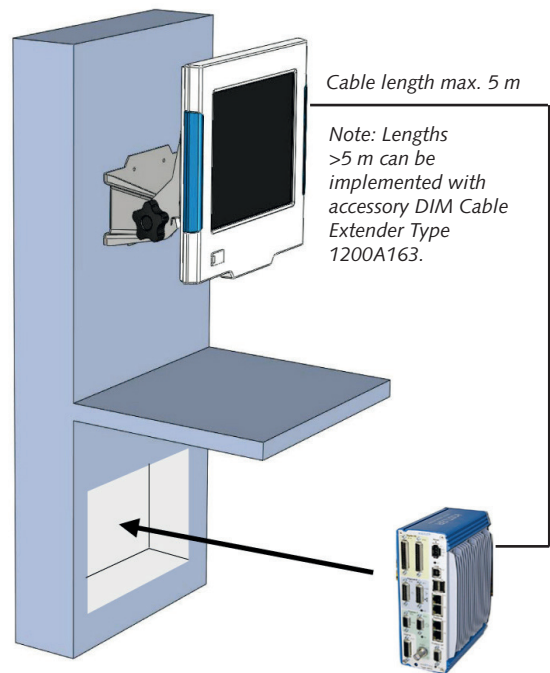

### Functional principle with DIM Cable Extender

DIM Cable Extender as an active cable extension between maXYmos MEM and Display DIM with a range of up to 100 m. The DIM Cable Extender Type 1200A163 is inserted into the rear panel of the maXYmos DIM Type 5877AZ000 display and fixed in place with two screws.

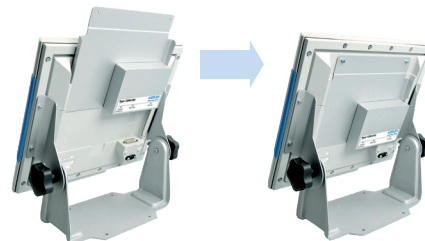

The DIM Cable Extender is inserted at the rear portion of the display. The DIM Cable Extender is supplied with 24 V of power (the display is then supplied by the DIM Cable Extender). The DIM Cable Extender is connected to one or several maXYmos units via an Ethernet cable.

5877B\_003-273e-05.20



**Dimensions**

Measuring and evaluation module (MEM)

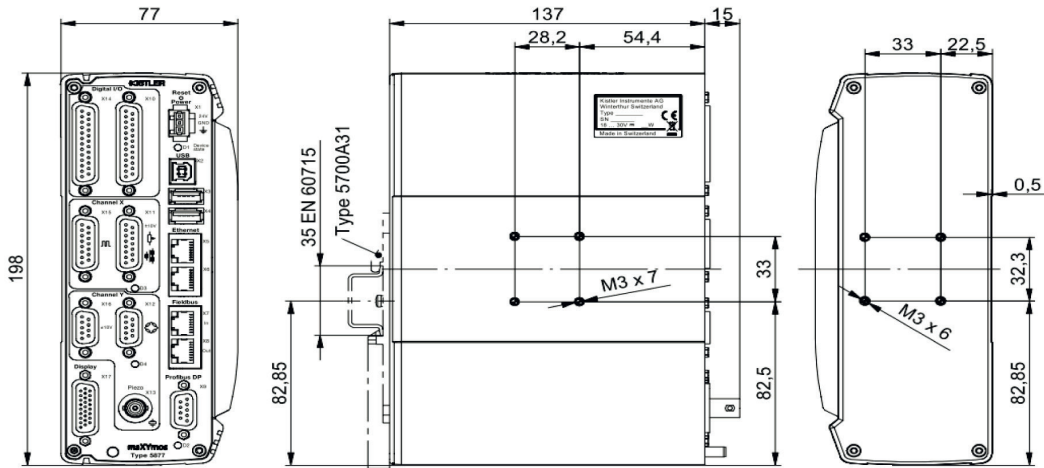

Note: Observe minimum spacing of >10 mm between the MEM's!

Display module (DIM)

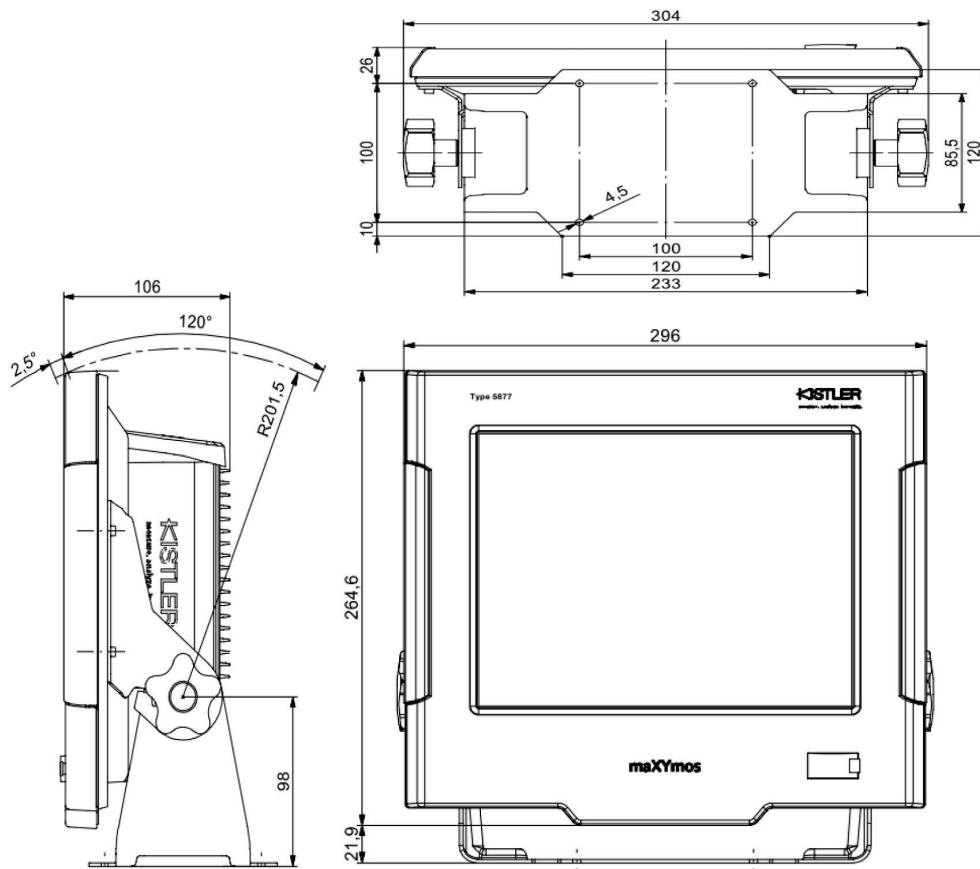

5877B\_003-273e-05.20

Display Module (DIM) switch panel mounting

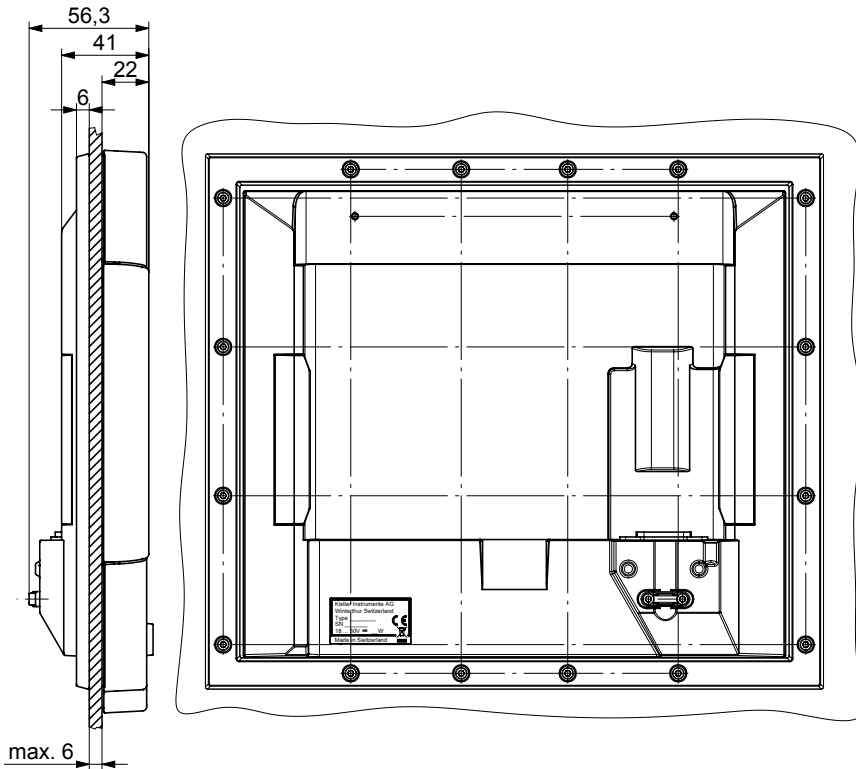

Display Module (DIM) – panel cut-out for switch panel mounting.  
With lateral distance to adjacent displays.

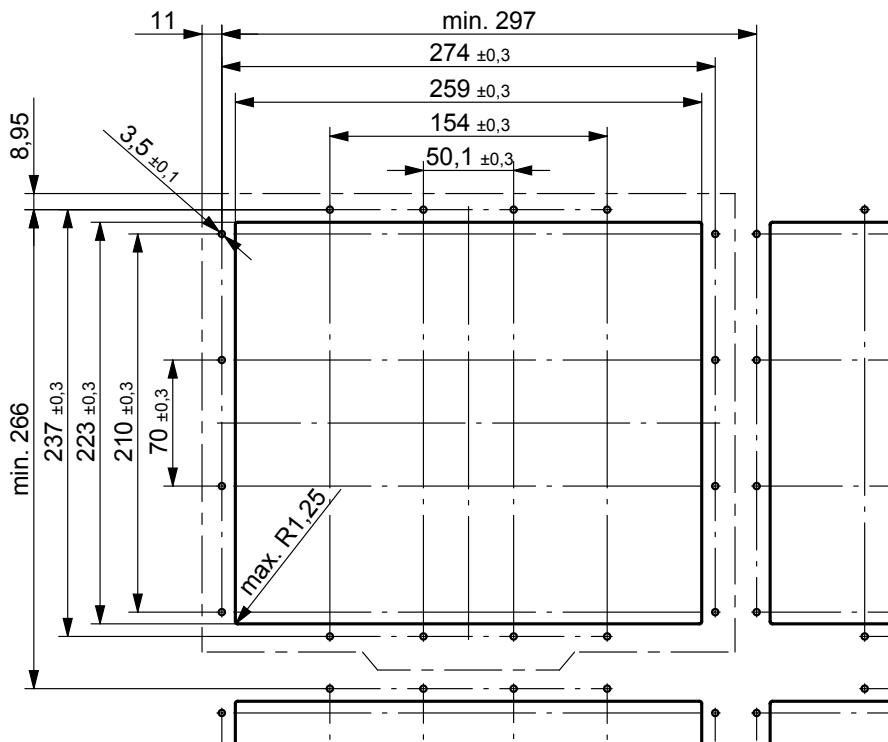

5877B\_003-273e-05.20

### Accessories

- Display module (DIM) Type 5877AZ000
- Set of connectors maXYmos TL for sensors, digital I/O and supply Type 5877AZ010
- Connecting cable between MEM and DIM, length 2,5 m Type 1200A161A2,5
- Connecting cable between MEM and DIM, length 5 m Type 1200A161A5
- Ethernet connecting cable between MEM's, length 0,5 m Type 1200A49A3
- Ethernet connecting cable between MEM's, length 5 m Type 1200A49
- Power supply 90 - 264 VAC/24 VDC ready for connection max. 90 W (3,75A), configurable country cable Type 5781B5
- DIN rail clip for MEM control cabinet mounting Type 5700A31
- DIM Cable Extender Type 1200A163

### Windows®-Software maXYmos PC (Basic) 2830A1

- Organize firmware updates
  - Save device settings in a backup file
  - Restore settings to the device
- (included in the scope of delivery of the measuring and evaluation module type 5877B)

### Windows®-Software maXYmos PC (Plus) 2830A2

- Like Basic version, but in addition:
- All device settings applied on PC (Setup editor)
  - Log explorer opens and interprets exported test records
  - Generation of an Excel® statistical file with selected process values
  - Cursor measurement, bundle presentation of curves, etc.
  - Final Y(X) curves can also be presented as Y(t) or X(t)
  - PDF print function for test records

### Included accessories for Type 5877B0 Type/Mat. No.

- Set of connectors maXYmos TL for sensors, digital I/O and supply Type 5877AZ010
- Windows software maXYmos PC Basis Type 2830A1
- Ethernet connecting cable between MEM's, length 0,5 m Type 1200A49A3

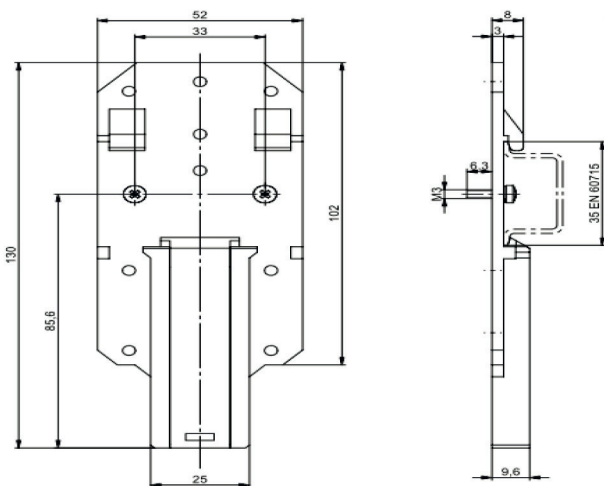

### Ordering key for

XY Monitor display module (DIM) Type 5877AZ000

### Ordering key for

Measuring and evaluation module XY Monitor maXYmos TL (MEM) Type 5877B

MEM maXYmos TL Standard	0
MEM maXYmos TL ML Medical Low measuring range	2
MEM maXYmos TL L Low measuring range	3