

**GORBEL**  
A CLASS ABOVE

The leader in crane technology  
and ergonomic lifting

PRECISION

01011010

SPEED

STRENGTH

INTELLIGENCE

10001001010010101011010

ELECTRIC  
SERVO  
POWERED  
INTELLIGENT  
LIFTING  
DEVICES

THE  
SMARTER  
WAY TO  
LIFT:  
G-FORCE® &  
EASY ARM®



# INTELLIGENT LIFTING TECHNOLOGY

Gorbel's G-Force® and Easy Arm® devices are part of an exciting new family of material handling equipment known as Intelligent Assist Devices (IADs). They use exclusive patented technology and an industrial processor controlled servo drive system to deliver unmatched lifting precision and speed. Their fusion of advanced technology and basic human guidance maximizes productivity while minimizing the risk of injury to the operator.

There are two models of Gorbel Intelligent Lifting Devices to choose from: the Q and the iQ. The Q model is our feature packed base model. It offers the same speed and precision as our higher-end iQ model, but without the added Input/Output features that the iQ offers. The iQ model offers a wealth of additional intelligence features.

**GORBEL**  
A CLASS ABOVE

Since 1977, Gorbel has specialized in overhead material handling solutions, providing the highest quality and the highest performance. We are the leading supplier of Work Station Crane systems, offering near perfect on-time delivery, a focus on customer service, and the industry's best warranty.

Now you'll find that same level of quality in our G-Force® and Easy Arm® Intelligent Lifting Devices. These innovative units enable operators to lift and maneuver naturally, as if the devices were an extension of their arms. Our Q and iQ model Intelligent Lifting Devices will help improve productivity, reduce the cost of product damage, and minimize work-related injuries.

[www.gorbel.com](http://www.gorbel.com)  
**800.821.0086**



### ANTI-RECOIL TECHNOLOGY

This prevents the G-Force® and Easy Arm® units from moving or recoiling when there is a sudden change in load, reducing the risk of potentially serious injury.

### INFINITE SPEED CONTROL

Gorbel's Intelligent Lifting Devices move with the operator. They move as fast or as slow as the operator chooses to move. They are ideal for applications that require high speed at some points in the cycle and slow, precise movements at other points.

### POWER LOSS PROTECTION

A fail safe load braking system locks the unit in place in the event of a power loss.

### BLAZING SPEEDS

With G-Force® speeds reaching 200 fpm (61 mpm) and Easy Arm® speeds reaching 180 fpm (55 mpm), these devices travel up to 4 times faster than traditional high-end lifting devices currently on the market, making them the fastest, most precise lifting devices on the planet.

### OPERATOR PRESENT FUNCTION

The handle grip of our Intelligent Lifting Devices uses a built-in photosensor that doesn't allow the unit to move unless the operator initiates the movement.

### CAPACITY OVERLOAD

The units will not lift if the load exceeds their rated capacity.

### THE SAFE ALTERNATIVE

Operators want to use our G-Force® technology because it's easy to learn and easy to use. Our Intelligent Lifting Devices are safer than manual lifting and dramatically reduce worker injury cost.

### PINPOINT PRECISION

Our Intelligent Lifting Devices deliver unparalleled precision with speeds of less than 1 fpm (0.3 mpm). This gives the operator the control necessary to finesse expensive or fragile parts.

### FLOAT MODE

The G-Force® and Easy Arm® units offer our versatile Float Mode. With a mere 1/2 lb (227 g) of force on the load itself, operators can precisely orient loads throughout the full stroke range by manipulating the load with their hands.



# G-FORCE

## G-FORCE® Q AND IQ BRIDGE CRANE MOUNTED INTELLIGENT LIFTING DEVICE

When precision, lifting power and speed are necessities, turn to Gorbels patented G-Force® Intelligent Lifting Device. More precise than hoists, more responsive than air balancers, our bridge crane mounted G-Force® units improve safety, productivity and quality, resulting in a direct increase to your bottom line.

### CHOOSE A BRIDGE MOUNTED CRANE CONFIGURATION FOR:

- Higher capacities: available in 165, 330, 660, and 1320 lb capacities
- Faster speeds: maximum speeds up to 200 fpm
- More responsive performance: faster acceleration and deceleration
- Covering multiple work cells with one G-Force®

### APPLICATIONS:

- Automotive assembly (engines, transmissions, chassis components)
- Heavy equipment manufacturing
- Tool & die changeouts
- Natural gas & oil industry (valves, drilling components, etc)
- Repetitive lifting jobs
- Parts assembly
- Machining
- Process equipment maintenance
- Covering larger single work areas

[www.gorbel.com](http://www.gorbel.com)

**800.821.0086**

## CASE STUDY

### G-FORCE® Q: DAMAGE AND INJURY RISK “VIRTUALLY” ELIMINATED



Atlas Copco's gas and process division makes turbo compressors and expansion turbines that are used for natural gas processing and power

generation. At an assembly facility where components for these large compressors are assembled, multiple work processes were sharing a single overhead crane system. Workers would often be at a stand-still while a co-worker used the crane, or would forgo the crane altogether and risk injury by lifting heavy parts by hand.

The company decided to target the highthroughput milling applications for a process change, and installed Gorbels work station cranes to eliminate the productivity delays caused by the shared crane. While the new cranes eliminated that problem, finding a lifting device to fit the application was a challenge due to the size of the load and the sensitive machinery it was being placed into.

In this work cell, 5-15" in diameter stainless steel cylinders that range from 15 to 400 pounds are milled down from bell shaped impeller blanks into the finished impeller with razor sharp edges. Moving the parts by hand posed multiple injury risks and a high potential for damage.

“We're lifting very heavy steel cylinders and trying to place them with precision into the milling machine without damaging the part or the machine,” said Diehl. “We needed something that gave us a lot of control.”

The company selected a 660 pound capacity G-Force® Q. Atlas Copco had considered other devices, but felt they would have the most control with the G-Force® after seeing a demo of the unit's virtual limits package, Float Mode feature, and overall smooth movement.

An operator now secures the impeller blanks into the tooling grip that Atlas Copco designed, which locks onto the blanks' outer rim. Once secured, the operator engages Float Mode on the G-Force® handle, and then moves the load up and down by holding the gripping tool or the load itself.





EASY ARM™

GORBEL®

# EASY ARM

## EASY ARM® Q AND IQ INTELLIGENT LIFTING ARM

The Easy Arm® Intelligent Lifting Arm is a combination of our G-Force® lifting device and an articulating jib crane. It is an ideal solution if you're looking for a turn-key, plug and play lifting solution. You get all the strength, precision, and speed of our patented G-Force® lifting technology and processor controlled electric servo drive system in the body of an ergonomic articulating jib crane.

### CHOOSE FREE STANDING EASY ARM® FOR:

- Smaller work areas that require 14' spans or less
- Capacities of 165, 330, and 660 lbs
- Easy installation: Unit ships assembled and ready to be installed
- No foundation required (some conditions apply, see Installation Manual)
- Easy relocation: the Easy Arm® is simply bolted to the floor



### CHOOSE UNDER HUNG EASY ARM® FOR:

- Saving valuable floor space
- Hook heights over 11'
- Covering multiple work cells

### APPLICATIONS:

- Reaching into a work cell or around obstructions
- Reaching under overhead obstructions like exhaust hoods
- Reaching into machines
- High cycle pick and place
- Loading/unloading machined parts

www.gorbel.com

800.821.0086

## CASE STUDY



### EASY ARM® Q: INCREASES PRODUCTIVITY, LIFTS 5X AS MANY PARTS



A major tier one auto parts supplier stamps round sheet metal blanks into clutch hubs and clutch housings for automatic transmissions.

The thin blanks range in diameter from 6-14" and weigh up to 8 pounds each.

They arrive in a bin and were manually loaded into the transfer press.

In order to load the blanks into the press, operators had to bend over the edge of the bin, grab as many blanks as they could hold, and then turn and carry them to the loading turn table. By the end of worker's shift, fatigue would set in and productivity would drop. Many workers complained of back strain and fatigue, while others suffered cuts to the hands, and wrist, plus elbow and shoulder pain.

After a new stamp press was installed, the company looked for a better handling solution. The company installed a 330 pound capacity Easy Arm® Q with an 8' span in the loading bay of their stamp press. The project integrator, Pressline Equipment, worked with Starquip of Ontario, Canada to design a pneumatic gripping tool that enabled operators to reach into the bin, grip about 150 pounds of blanks and effortlessly guide them into the spindles on the loading table. This is about 5-times as many blanks as they were able to lift manually. The result was faster cycle times, less worker fatigue, and no more productivity drop-off near the end of a shift.

"We were very pleased with the initial results," said the company's Environmental, Health & Safety Manager. "We had no more repetitive use injuries among Easy Arm® users, and workers are moving faster with less fatigue. We have older ladies who are able to do this job now with no problems. We wouldn't be buying a second unit if we had any doubts about it."

#### <<< Portable Base

Instead of bolting your free standing unit to the floor, our optional portable base gives you a stable base that you can move anywhere in your facility. The base shown is for smaller Easy Arms. Larger units may require a different portable base. Contact your Gobel dealer to learn more.





## INNOVATIVE HANDLE DESIGN

### G 360™ Swivel Assembly

Our G-Force® Intelligent Lifting Devices have a combined collector/air swivel that allows the handle to continuously rotate without damaging electrical conductors in the coil cord or optional air coil. This is ideal in applications where the operator is continuously rotating the handle.

### LCD Display

Backlit display on the handle allows for menu style set up of features like Virtual Limits and Speed Reduction Points. It also communicates valuable information like operation modes, weight readout, diagnostic information, and fault codes.

### Operator Present Function

The handle grip of our Intelligent Lifting Devices uses a built in photo sensor, making it safe and intuitive. This method senses the presence of the operator's hand without a physical lever to depress. The result is safe, smooth operation because the operator is not tempted to use the Operator Present Sensor safety feature as a start/stop control.

### Ergonomic Handle Design

Our long lasting handle was designed with your operator's comfort in mind. Its shape, size, and material were carefully planned to fit comfortably in the curve of your hand, while its rubber, textured coating gives you a positive grip.



## Q AND IQ HANDLE CONFIGURATION OPTIONS

The G-Force® and Easy Arm® were designed to provide flexibility in handle configurations. Your Gorbel distributor or your tooling integrator can help you choose the handle configuration best suited for your application.

See tooling examples on pages 15-16.



### In-Line Slide Handle

The in-line slide handle allows the operator to get close to the load for more control and precision. With this handle, the load moves with the motion of the operator's hand.



### Remote Mount Slide Handle

This configuration offers the same smooth control as the slide handle, but accommodates set-ups where the operators can't be close to the load.



### Suspended Pendant Control Handle

This handle is ideal when you have limited headroom, when the operator can't get close to the load or when the operator needs maximum lifting stroke. This handle can also be used when you expect the load to bounce or tip during lifting.



### Remote Mount Pendant Control Handle

Choose this design when the handle is mounted more than one foot from where the wire rope attaches to tooling, or when you expect the load to bounce or tip during lifting.

## FORCE SENSING HANDLES FOR G-FORCE® AND EASY ARM®

The Force Sensing Handles offer versatility in ergonomic lifting. Compared to standard slide handles, which use displacement of the handle to initiate upward or downward motion, the new design senses force applied without any handle motion. This creates a versatile option for tooling, or elongated handles that perfectly serve applications with a wide range of motion.



### In-Line (FSI)

When very low or very high pick and place points require hand-over-hand lifting. Eliminates the need to bend over to reach into deep bins or dunnage.



### Hub (FSH)

Provides the most flexibility for custom tooling solutions by allowing a wide range of handle bars (by others) to be mounted to the hub. The hub can also be mounted anywhere on the custom tooling frame. When the operator needs to control up/down motion by applying force to any point on the handle bars or other control fixtures attached at the hub.



### Remote mounted (FSR)

Provides the ability to remote mount a 24" or 36" Force Sensing Handle to a tooling frame (by others). This is beneficial for ergonomically reaching high and low pick/place points.

## G-FORCE® Q AND IQ: BRIDGE CRANE MOUNTED LIFTING DEVICE

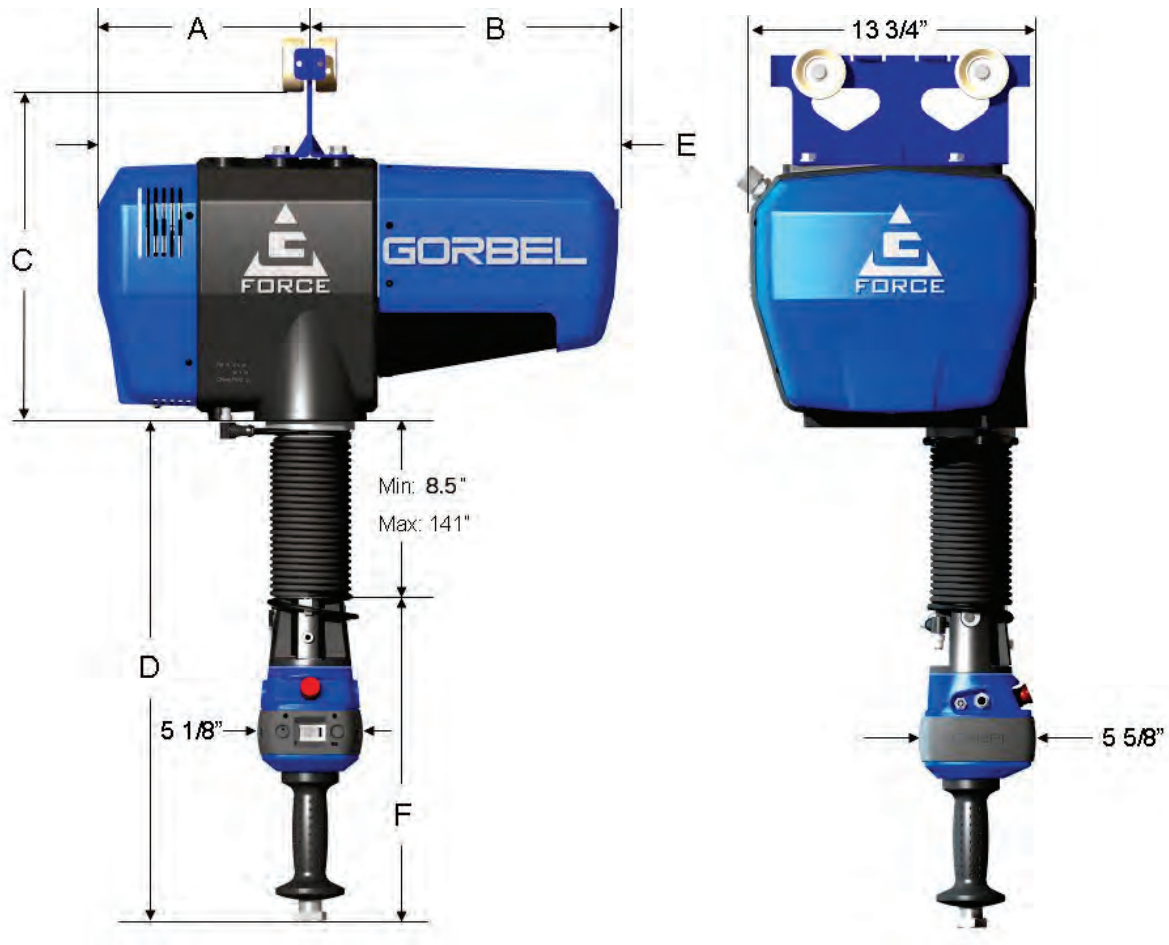

Capacity	165 lb (75 kg)	330 lb (150 kg)	660 lb (300 kg)
A	8.625" (219mm)	10.25" (260mm)	10.25" (260mm)
B	14.375" (365)	15" (381)	15" (381)
C	17" (432)	17" (432)	17" (432)
D	26" (660)	26" (660)	26" (660)
E	23" (584)	25.25" (641)	25.25" (641)
F	16" (406)	16" (406)	16" (406)

C dimension may change according to the track series you're using. Consult factory for actual dimension.  
D references unit in full up position.

www.gorbel.com  
800.821.0086

# HANDLE CONFIGURATION OPTIONS



Dim	Remote Mount Slide	Suspended Pendant Control	Remote Mount Pendant Control
D	17.5" (445mm)	8.5" (216mm)	17.5" (445mm)
F	14.25" (362)	14" (356)	14" (356)



## FORCE SENSING HANDLES

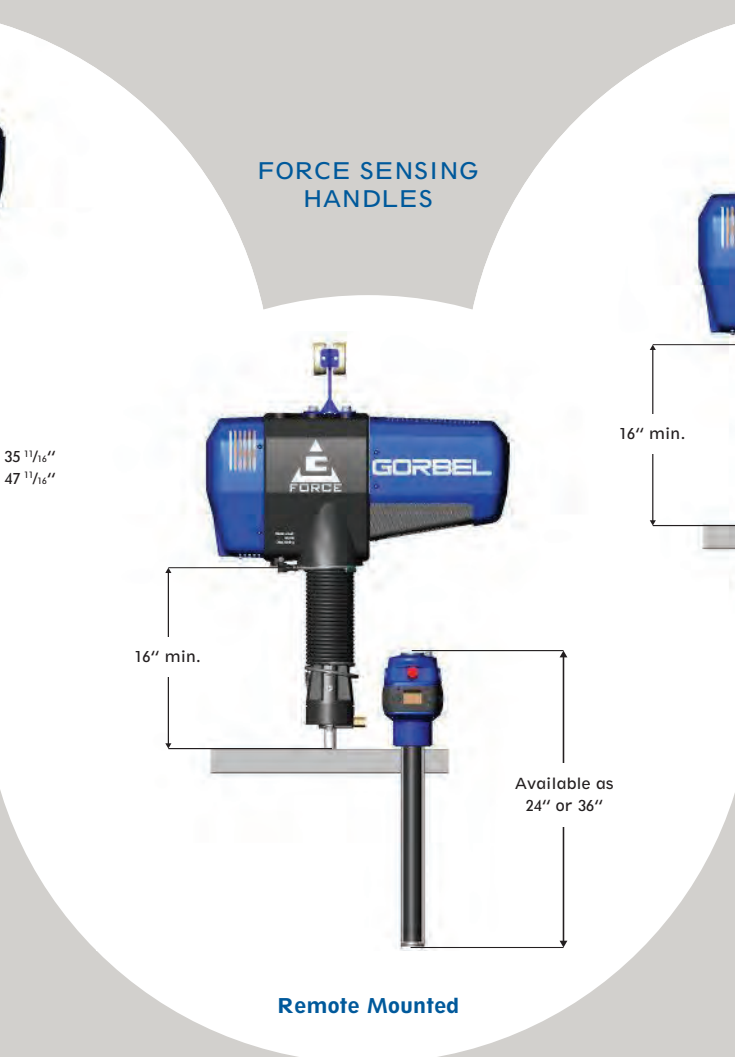

# 1320 LB. UNIT HANDLE CONFIGURATIONS



In-Line Slide



Remote Slide

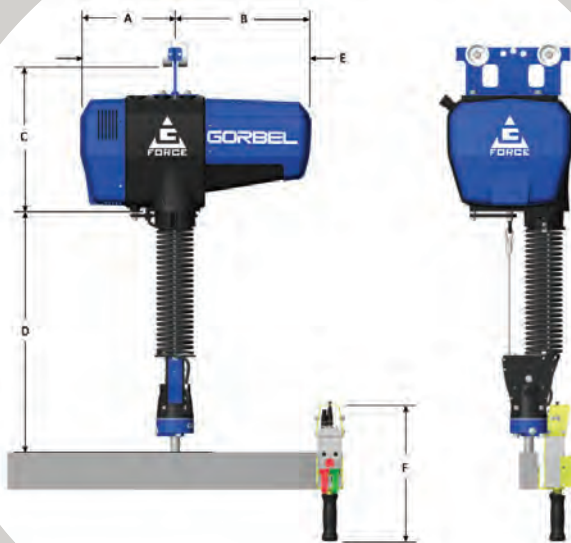

Remote Pendant



Suspended Pendant

Dim	In-Line Slide	Remote Slide	Remote Pendant	Suspended Pendant
A	10.25" (260mm)	10.25" (260mm)	10.25" (260mm)	10.25" (260mm)
B	15" (381)	15" (381)	15" (381)	15" (381)
C	17" (432)	17" (432)	17" (432)	17" (432)
D	30.5" (775)	21.5" (546)	21.5" (546)	17.5" (445)
E	25.25" (641)	25.25" (641)	25.25" (641)	25.25" (641)
F	19.5" (495)	14.25" (362)	14" (356)	14" (356)

## CASE STUDY

### G-FORCE® Q: ERGONOMIC- FRIENDLY, INCREASES PRODUCTIVITY



An international distributor of sustainable, environmentally friendly office space was looking to optimize the safety of its employees in high risk applications. One of the first areas targeted was the raw material receiving area, which handles incoming sheets of glass that are usually 3 feet by 6 feet, and weigh about 115 pounds. The sheets are brought in on large A frames, and moved onto carts where they go on to be framed.

Shipments are received a few times each week, and two workers are required to do as many as 80 lifts each shift. It was clear to the management very early that there was too much at risk to leave the application as it was.

“We had a few small injuries,” said the manufacturing manager. “We did not have any back injuries yet, but it was coming. We didn’t want to wait for it.”

“A very similar application in another facility used a crane as well, but they had a chain hoist to lift the glass. It was very slow, not smooth enough, and operators didn’t feel they had enough control to set the glass down gently. Eventually the workers pushed it off to the side.”

For this facility, the company purchased a Gorbelt G Force® Q with 330 pound lifting capacity and a remote mounted handle integrated with a Schmalz vacuum lifter. The tooling allows a single user to grip the sheet of glass and tilt it into position. The range of motion of the G Force® allows the users to maintain a fast working pace while still carefully placing each sheet of glass onto the carts. Since installing the G Force®, the management is very satisfied with the results, and the workers were also very happy to have the new lifting method.

“I am very happy with it,” said one of the operators. “Especially on the larger pieces of glass, it saves us a lot of personnel time. We’re able to run things a lot smoother, able to move from job to job and not worry about maneuvering the a frames because of the different sizes of glass.”



[www.gorbelt.com](http://www.gorbelt.com)

800.821.0086

# EASY ARM

## EASY ARM® Q AND IQ: FREE STANDING LIFTING DEVICE

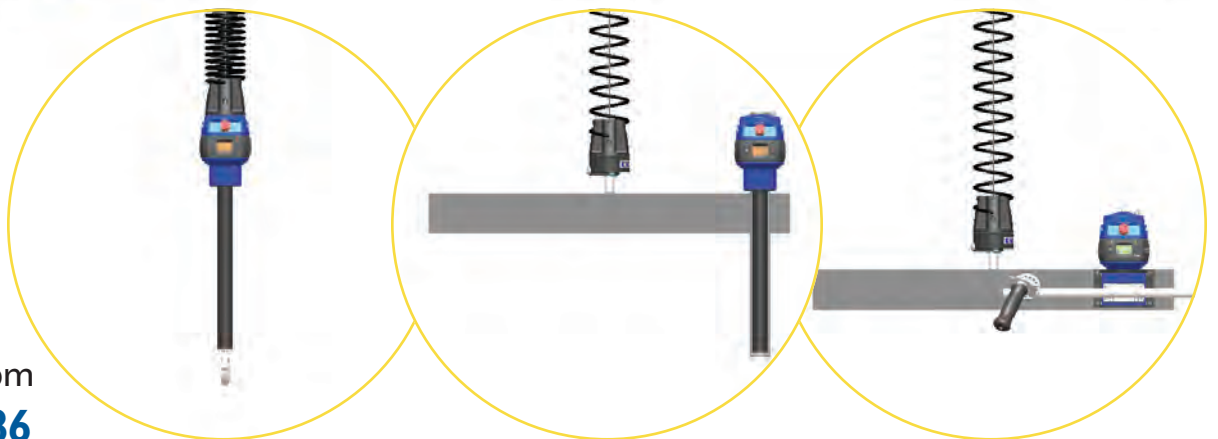
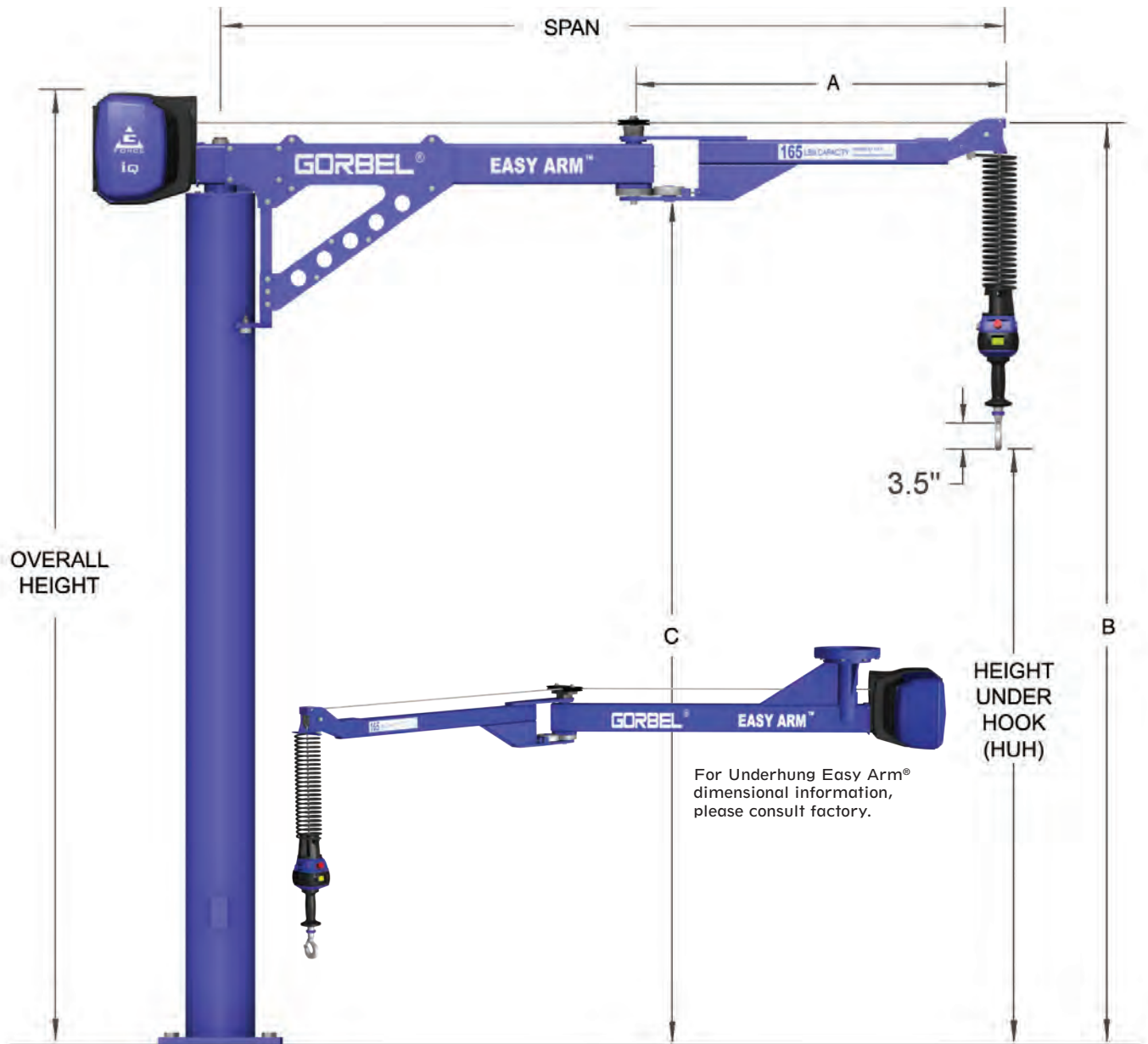

www.gorbel.com  
800.821.0086

## 165 LB (75 KG) UNIT

Span	6'	8'	10'	12'	14'	6'	8'	10'	12'	14'	6'	8'	10'	12'	14'
	(1829mm)	(2438mm)	(3048mm)	(3658mm)	(4267mm)	(1829mm)	(2438mm)	(3048mm)	(3658mm)	(4267mm)	(1829mm)	(2438mm)	(3048mm)	(3658mm)	(4267mm)
HUH	6' (1829)					8' (2438)					10' (3048)				
OAH	109.14" (2772)					133.14" (3382)					157.14" (3991)				
A	33.84" (860)	45.12" (1146)	56.40" (1433)	67.68" (1719)	78.96" (2006)	33.84" (860)	45.12" (1146)	56.40" (1433)	67.68" (1719)	78.96" (2006)	33.84" (860)	45.12" (1146)	56.40" (1433)	67.68" (1719)	78.96" (2006)
B	105.98" (2692)					129.98" (3301)					153.98" (3911)				
C	97.89" (2486)					121.89 (3096)					145.89" (3706)				
D	24.90" (632)	32.06" (814)	40.03" (1017)	48.00" (1219)	56" (1422)	24.90" (632)	32.06" (814)	40.03" (1017)	48.00" (1219)	56" (1422)	24.90" (632)	32.06" (814)	40.03" (1017)	48.00" (1219)	56" (1422)

## 330 LB. (150 KG) UNIT

Span	6'	8'	10'	12'	14'	6'	8'	10'	12'	14'	6'	8'	10'	12'	14'
	(1829mm)	(2438mm)	(3048mm)	(3658mm)	(4267mm)	(1829mm)	(2438mm)	(3048mm)	(3658mm)	(4267mm)	(1829mm)	(2438mm)	(3048mm)	(3658mm)	(4267mm)
HUH	6' (1829)					8' (2438)					10' (3048)				
OAH	109.88" (2791)					133.88" (3401)					157.88" (4010)				
A	33.84" (860)	45.12" (1146)	56.40" (1433)	67.68" (1719)	78.96" (2006)	33.84" (860)	45.12" (1146)	56.40" (1433)	67.68" (1719)	78.96" (2006)	33.84" (860)	45.12" (1146)	56.40" (1433)	67.68" (1719)	78.96" (2006)
B	106.86" (2714)					130.86" (3324)					154.86" (3933)				
C	97.77" (2483)					121.77" (3093)					145.77" (3703)				
D	24.34" (618)	32.26" (819)	42.70" (1085)	51.48" (1308)	59.76" (1518)	24.34" (618)	32.26" (819)	42.70" (1085)	51.48" (1308)	59.76" (1518)	24.34" (618)	32.26" (819)	42.70" (1085)	51.48" (1308)	59.76" (1518)

Please note:

These dimensions are for Easy Arm® units with in-line slide handles only. Units with suspended pendant handles will have different dimensions. Please contact Corbel at (800) 821-0086 for these dimensions. Other Heights Under Hook are available as special orders; contact factory. Dimensions shown in parentheses are in millimeters.

## 660 LB. (300 KG) UNIT

Span	8'	10'	12'	14'	8'	10'	12'	14'	8'	10'	12'	14'
	(2438mm)	(3048mm)	(3658mm)	(4267mm)	(2438mm)	(3048mm)	(3658mm)	(4267mm)	(2438mm)	(3048mm)	(3658mm)	(4267mm)
HUH	6' (1829)				8' (2438)				10' (3048)			
OAH	122" (3099)				146" (3708)				170" (4318)			
A	45.12" (1146)	56.4" (1433)	67.68" (1719)	78.96" (2006)	45.12" (1146)	56.4" (1433)	67.68" (1719)	78.96" (2006)	45.12" (1146)	56.4" (1433)	67.68" (1719)	78.96" (2006)
B	114.22" (2901)				138.22" (3511)				162.22" (4120)			
C	94.39" (2398)		91.66" (2329)		118.39" (3007)		115.66" (2938)		142.39" (3617)		139.66" (3547)	
D	40.1" (1019)	50.1" (1273)	60.1" (1527)	70.1" (1781)	40.1" (1019)	50.1" (1273)	60.1" (1527)	70.1" (1781)	40.1" (1019)	50.1" (1273)	60.1" (1527)	70.1" (1781)

## BASEPLATE DIMENSIONS

Please note: Hex baseplates are used on all 330 lb units, and on 165 lb units with a combined HUH plus span of 18' or more. All other 165 lb units use a square baseplate.

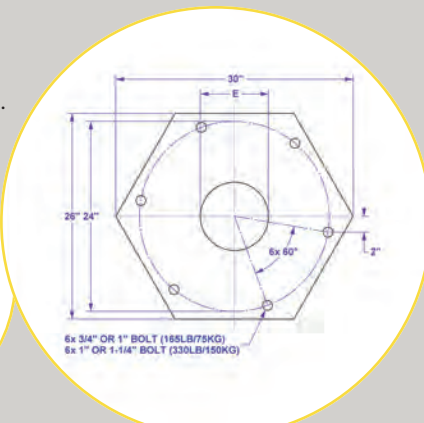
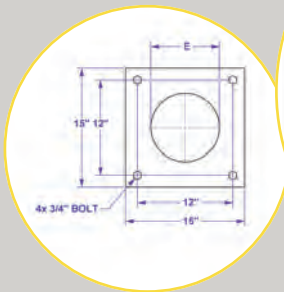

## HOOK COVERAGE

Arm Rotation:  
355° primary arm  
320° secondary arm

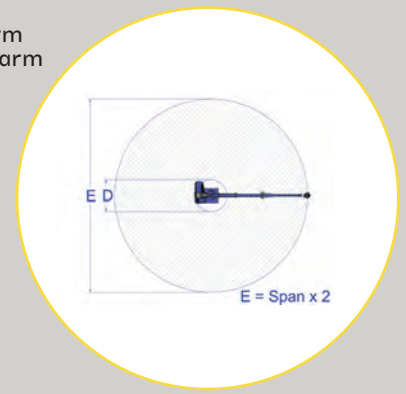

# TOOLING

## EASE OF TOOLING INTEGRATION

### GORBEL'S G-FORCE® TOOLING EXAMPLES

The Q and iQ units were designed with tooling integration in mind. Optional handle auxiliary control brackets allow pneumatic valves or electric switches to be integrated with the G-Force® control handles. Choose one of these three handle configurations to meet the needs of your applications.

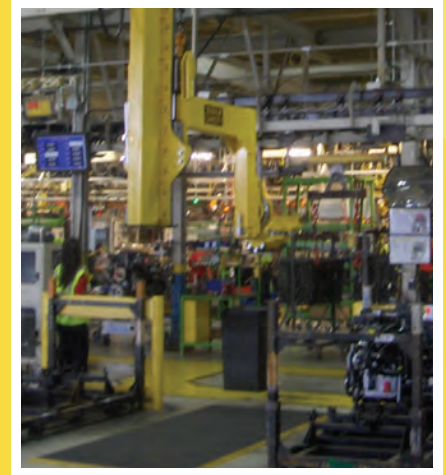
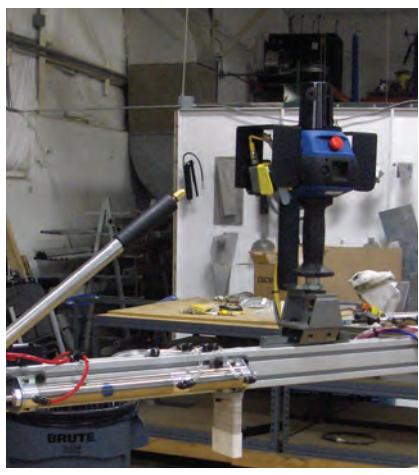

[www.gorbel.com](http://www.gorbel.com)  
**800.821.0086**



## SOFT TOUCH CONTROL HANDLES MAKE TOOLING INTEGRATION EASIER

Use our Soft Touch Control Handles to control any air or electric powered equipment, such as end-effector tooling for the G-Force® or Easy Arm®. A common handle base for air or electric applications gives you design commonality and flexibility, whether your application requires air valves for direct control of end tooling, or electric switches to activate your G-Force® or Easy Arm® iQ inputs.



### Why choose a Soft Touch Control Handle?

- Flexible design easily integrates into new equipment layouts
- Easy replacement of any standard pneumatic or electric handles
- Engineered for easy use to reduce potential for fatigue and repetitive stress injuries
- Offers more flexibility in tooling choices and the ability to customize tooling for applications
- Costs less than most comparable handles

# GORBEL'S G-FORCE® TECHNOLOGY: PROVEN PERFORMANCE

## ERGONOMIC STUDY

The following summary is based on a study performed by the Rochester Institute of Technology. The study compared the performance of Gorbels G-Force® Intelligent Lifting Device to other lifting devices. It focused on High Cycle Applications and Precision Placement Applications. To read the whole study, go to: <http://www.gorbel.com/pdfs/study/gforceergostudy.pdf>.

### High Cycle Test

Operators were:

- **124%** more productive with the G-Force® than with air balancers
- **74%** more productive with the G-Force® than with variable frequency drive hoists

\* Manual: 75% of the subjects could not complete 10 minutes of lifting & still maintain safe heart rates.

### Precision Placement Test

Operators were:

- **76%** more productive with the G-Force® than with air balancers
- **59%** more productive with the G-Force® than with variable frequency drive hoists

\* Manual: None of the subjects could complete 10 minutes of lifting w/o exceeding safe heart rates.

### Force of Placement

The G-Force® was:

- **2.5x** less likely to damage the load than the air balancer with pendant control
- **3.3x** less likely to damage the load than the variable frequency drive hoists
- **2.2x** less likely to damage the load than manual

[www.gorbel.com](http://www.gorbel.com)  
**800.821.0086**

Figure 1: Number of Palletizing Lifts  
(Normalized for Energy Expenditure)

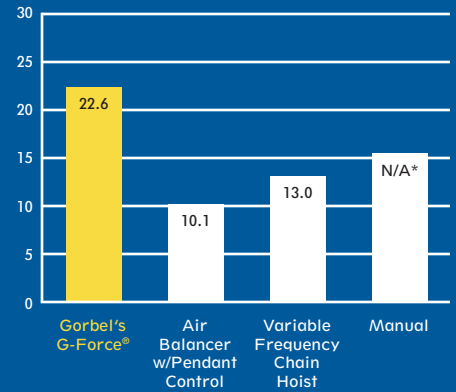

Figure 2: Number of Precision Placement Lifts

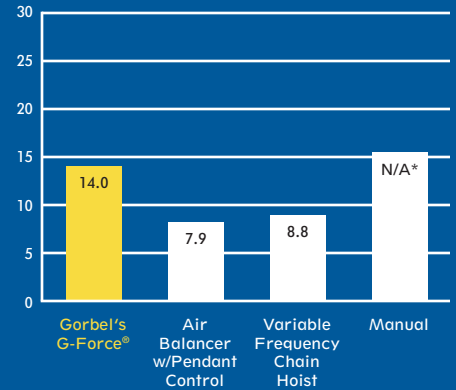
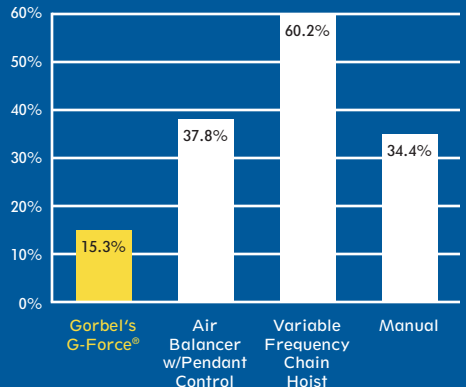

Figure 3: Percentage of Lifts Exceeding Force Threshold



# GORBEL'S Q AND IQ TECHNOLOGY: TECHNICAL SPECIFICATIONS

## BRIDGE MOUNTED G-FORCE® Q AND IQ QUICK FACTS

G-Force®	Q	iQ	Q	iQ	Q	iQ	Q	iQ
Maximum Capacity (Load & Tool)	165 lb		330 lb		660 lb		1320 lb	
	75 kg		150 kg		300 kg		600 kg	
Maximum Lifting Speed Unloaded	200 ft/min		100 ft/min		50 ft/min		25 fpm	
	61 m/min		30 m/min		14.94 m/min		7.47 m/min	
Maximum Lifting Speed Fully Loaded	125 ft/min		75 ft/min		42 ft/min		21 fpm	
	38 m/min		23 m/min		12.80 m/min		6.4 m/min	
Maximum Float Mode Lifting Speed	103 ft/min		65 ft/min		38 ft/min		19 fpm	
	31 m/min		20 m/min		11.58 m/min		5.79 m/min	
Maximum Lift Range	11 ft		11 ft		11 ft		5.5 ft	
	3.35 m		3.35 m		3.35 m		1.68 m	

## FREE STANDING EASY ARM® Q AND IQ QUICK FACTS

Easy Arm®	Q	iQ	Q	iQ
Maximum Capacity (Load & Tool)	165 lb		330 lb	
	75 kg		150 kg	
Maximum Lifting Speed Unloaded	180 ft/min		90 ft/min	
	55 m/min		27 m/min	
Maximum Lifting Speed Fully Loaded	125 ft/min		75 ft/min	
	38 m/min		23 m/min	
Maximum Float Mode Lifting Speed	103 ft/min		65 ft/min	
	31 m/min		20 m/min	
Maximum Lift Range	11 ft		11 ft	
	3.35 m		3.35 m	

## Q AND IQ TECHNICAL SPECS

G-Force® and Easy Arm®	Q	iQ
Primary Lift Voltage (VAC)	220 +/- 10%	
Maximum Current (Amps)	10	
Duty Cycle	H5	
Operating Temperature Range	41 - 122° F 5 - 50° C	
Operating Humidity Range (Non-Condensing)	35 - 90%	
User Accessible Power	Not Available	24VDC @ 0.5A
Virtual Limits (Upper Limit, Power Limit, Speed Reduction)	Standard	Standard

## IQ SPECIFIC INFORMATION

I/O Actuator (iQ Only)	iQ
Number of Inputs, Type	8, Sinking
Input Current @ 24 VDC	6ma
Number of Outputs, Type	8, FET
Continuous Current/Channel (Amps)	0.5
Module Maximum Current (Amps)	0.5
Handle with I/O Module (iQ Only)	iQ
Number of Inputs, Type	8, Sinking
Input Current @ 24 VDC	4ma
Number of Outputs, Type	8, FET
Continuous Current/Channel (Amps)	0.5
Module Maximum Current (Amps)	0.5

**FOR MORE INFORMATION**

Your authorized Gorbel dealer can give you more information on what makes Gorbel's Ergonomic Work Station Cranes and other material handling products "A Class Above."

**OVERVIEW**



**BRIDGE CRANES**



Work Station Cranes



Cleveland Tramrail



Ergonomic Study

**ERGONOMIC LIFTING**



G-Force® & Easy Arm®



Ergonomic Study

**JIB CRANES**



Jib Cranes

**FALL PROTECTION**



Fall Arrest

**GORBEL**

600 Fishers Run  
PO Box 593  
Fishers, NY 14453 USA  
† 585.924.6262  
f 585.924.6273  
info@gorbel.com

www.gorbel.com  
**800.821.0086**